



# Nobita Light 2.0 Installation & Onboarding Manual



# Thank you for choosing **Nobi**

This document provides the key information you need for a smooth installation of the **Nobita Light 2.0**.

For onboarding explanations, visit:

<https://tinyurl.com/4cp37375>



## Table of contents

Preparation .....	3
Safety precautions .....	4
Pre-installation .....	5
Mounting the Nobi Power .....	6
Attaching the Nobita Light .....	7
Onboarding the Nobita Light .....	8
Warnings .....	10

### Contact Nobi



#### General questions

Take a look at our frequently asked questions and answers:  
[nobi.life/frequently-asked-questions](https://nobi.life/frequently-asked-questions)



#### Support

For technical support during installation, contact Nobi Support: [support@nobi.life](mailto:support@nobi.life)

# Preparation

## Contents:

- Nobita Light
- Nobi Power



Nobita  
Light



Nobi  
Power

## Required tools (not included):

- Multimeter
- Pencil
- Hammer
- Screwdriver
- Power drill
- Cable cutter
- Ladder
- Spirit level
- If there is no ceiling box or ceiling adapter, use appropriate plugs and screws suitable for the ceiling material:
  - 4 plugs (3/16")
  - 4 screws (M4)
- Mobile device (for onboarding purposes)

---

## Estimated time:

- Installing the Nobita Light — 45 minutes
- Onboarding — 5 minutes

## Before you begin:

- **Read all safety precautions** before starting the installation.
- The use of this manual is **restricted to Nobi Customer Services, authorized Nobi resellers, and technically trained individuals** who have received official Nobi installation training.
- Always onboard the Nobi Pendant Light or Nobi Ceiling Light before the Nobita Light.
- Install a Nobi switch to control the Nobi Light. This will add 10 minutes to the installation time.

# Safety precautions

Read the following safety precautions carefully before installing the Nobita 2.0  

- Take care when installing the Nobita as there is a risk of electric shock.
- This product must be installed in accordance with the applicable installation code by a person familiar with the construction and operation of the product and the hazards involved.
- The Nobita must be installed in an electrical circuit that contains a fuse with a minimum contact separation of 1/10" (3 mm).
- Do not install the Nobita in a closet.
- The Nobita is designed for indoor use only.
- The Nobita must be mounted on the ceiling.
- The light source in this luminaire should only be replaced by the manufacturer, its service agent or a similarly qualified person.
- Install the Nobita out of arm's reach.
- Once installed, the equipment is not intended for direct physical contact by any person.

# Installing the Nobita 2.0



## Pre-installation

- 1** **Locate the main circuit breaker box and switch off the electrical power.**  
To cut off power to individual rooms or circuits, switch the branch fuse to the OFF position.

Use a multimeter (or a known connected switch) to **verify** that the **power is fully disconnected**.

- 2** **Remove the current light fixture (if present), exposing 3 electrical wires:** ground (green or bare), neutral (white), and switched hot (black).  
Make sure you can identify each wire correctly. The colors may vary by country or local regulations. Tape or cap any unused ground wires.

**Notice:** The switched line must be bridged to the live line behind the switch controlling the lighting point where the Nobita Light will be installed, ensuring the lighting point has constant mains voltage (100 V-240 V).

- 3** **Take the Nobi Power out of the box.**

# Mounting the Nobi Power

**4** → If a **CEILING BOX** (US) is **PRESENT** or an existing light is replaced:  
**Connect the ceiling adapter to the ceiling box** using the 2 screws provided with the ceiling box.

→ If **NO CEILING BOX** is **PRESENT**, or if you are installing a new light:  
Hold the Nobi Power against the ceiling and **mark the 4 drill holes** with a pencil.

**Drill the holes** to the appropriate depth using a 15/64" or 6.0 mm drill bit at the marked points.

Carefully **tap the plugs** into the drilled holes.

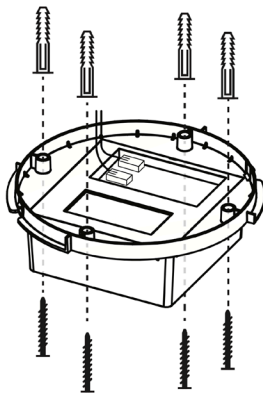

Precise marking is critical to the accuracy and ease of the subsequent steps.

**5** Hold the Nobi Power against the ceiling near the outgoing electrical wires.

**6** **Connect the electrical wires** to the Nobi Power by using the 2 connectors. Connect the switched hot (black) wire and the neutral wire (white) to the appropriate wires on the Nobi Power. Do not connect them to the same connector. The ground wire (green or bare) should not be connected. Tape or cap any unused ground wires.

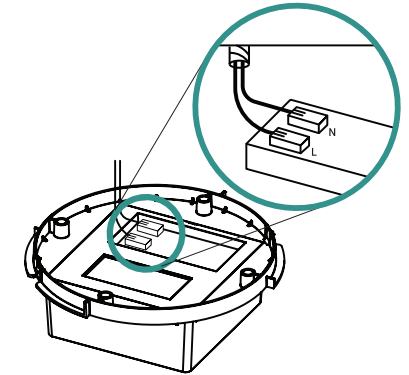

**7** **Mount the Nobi Power with the four screws.**

→ If a **CEILING BOX** (US) is **PRESENT** or an existing light is replaced:  
Use the 4 included metric screws.

→ If **NO CEILING BOX** is **PRESENT** or a new light is being installed:  
Use 4 screws that are applicable to the ceiling material being used.

Tighten the screws, ensuring the Nobi Power is firmly fixed to the ceiling.  
Use all 4 screws for a sturdy installation.

**8** **Switch the fuse back on.**  
A small green light on the Nobi Power will illuminate.

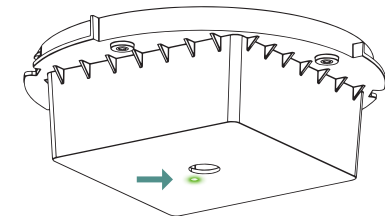

# Attaching the Nobita Light

**9** Place the Nobita Light over the Nobita Power<sup>1</sup>, turn it 90° to the right<sup>2</sup>, and gently pull down<sup>3</sup> to secure it.

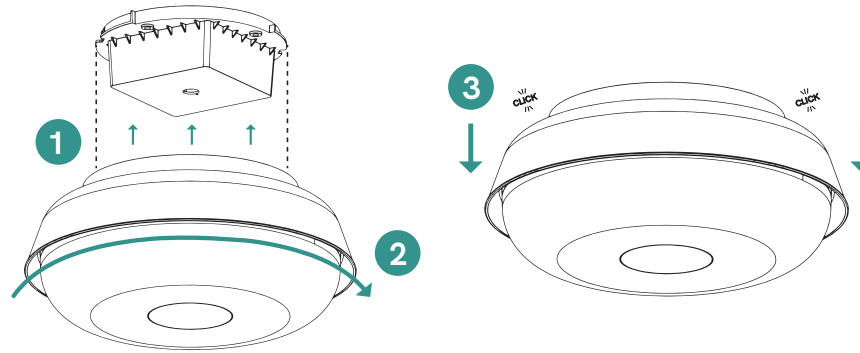

**10** The Nobita Light will first flicker white and then flash blue.

**11** Remove the protective plastic on the underside of the Nobita Light. You are ready to start onboarding.

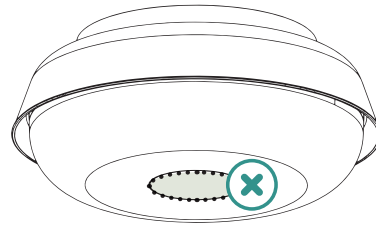

# Onboarding the Nobita light



Before you begin the onboarding process:

1. **Contact your local distributor or Nobi** before starting the onboarding process, as your account must be created by them first.
2. **Download** the app:



# Onboarding the Nobita light

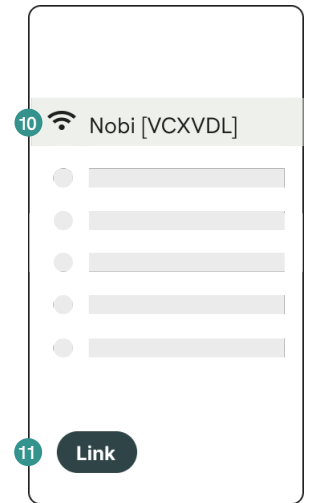
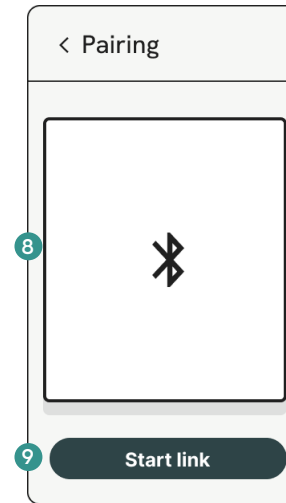
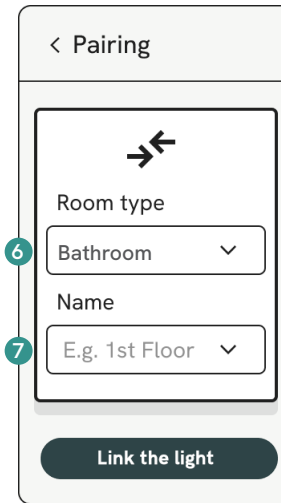
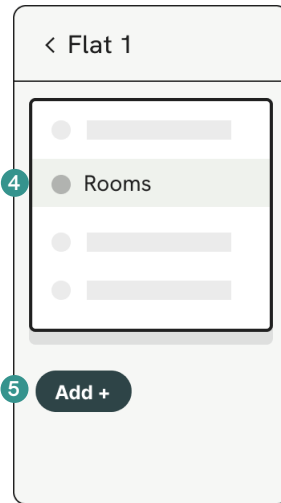
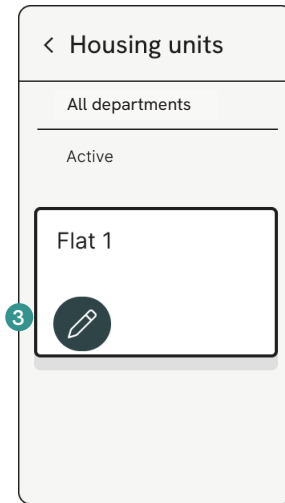
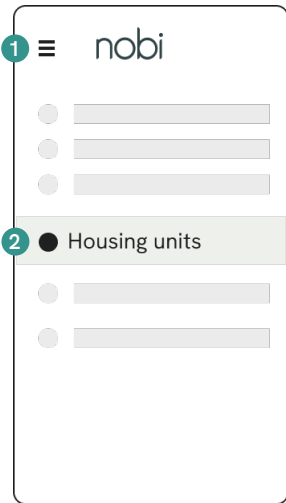

## After the onboarding:

**An update may occur;** its duration depends on your WiFi network's capacity. This update occurs in the background and may impact the availability of new features.

# Warnings on the Nobita Light

## Symbols

	Consult manual before use		Nobita Light mount use only		CE marking		Recycling
	Caution, risk of electric shock		Indoor use only		UK Conformity Assessed		Warning sign
	Class II		Emits IR light		Location of manufacturing		Read manual before use
	Class III		FCC marking		Recycling		DC polarity
	Do not stare at the light source		Caution is needed when installing and using this device; consult the manual before use				

## Environmental conditions

- Operating temperature: 50 °F to 104 °F (10 °C to 40 °C)
- Operating humidity: 15% to 95% RH (non-condensing)
- Atmospheric pressure: 9.6 to 15.4 psi (66 kPa to 106 kPa) and maximum 6560 ft (2000 m) altitude

## Technical specifications

### Nobita Light 2.0

#### Input

- 24 V DC
- Max 0.9 A
- Max 21 W

### Nobi Power

#### Input

- 100-120 V AC (UL)
- 220-240 V AC (EU)
- 50/60 Hz
- Max 1.7 A

#### Output

- 24 V DC
- Max 3.35 A

## Label

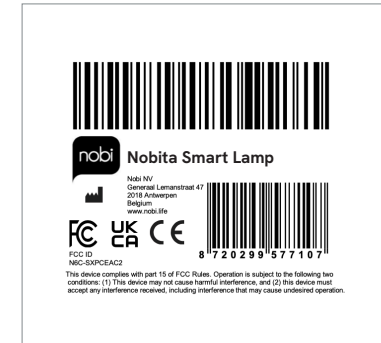
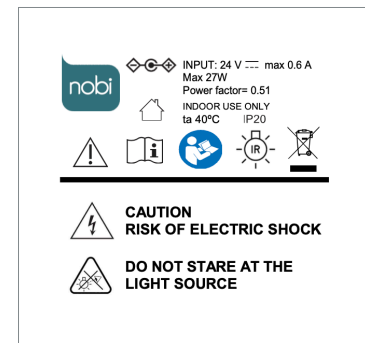
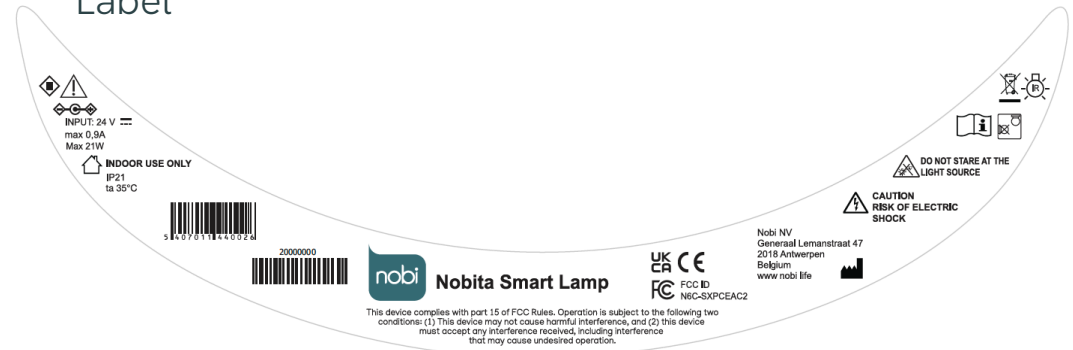

## Disposal message

Your product is designed and manufactured with high quality materials and components, which can be recycled and reused. Please find out for yourself about the local separate collection system for electrical and electronic products. Please act according to your local rules and do not dispose of your old products with your normal Household waste. The correct disposal of your old product will help prevent potential negative consequences for the environment and human health.