



# Nobi Power 2.1 Installation Manual



# Thank you for choosing **Nobi**

This document provides the key information you need for a smooth installation of the **Nobi Power 2.1**.

## Table of contents

Preparation .....	3
Pre-installation .....	4
Mounting the Nobi Power .....	5
Warnings .....	6

### Contact Nobi



#### General questions

Take a look at our frequently asked questions and answers:  
[nobi.life/frequently-asked-questions](https://nobi.life/frequently-asked-questions)



#### Support

For technical support during installation, contact Nobi Support: [support@nobi.life](mailto:support@nobi.life)

# Preparation

## Contents:

### BOX B

- Nobi Power with 2 connectors (Wago — UL listed)
- Ceiling Adapter
- 4 metric screws



Nobi Power



Ceiling Adapter

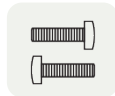

4 Metric screws

## Required tools (not included):

- Multimeter
- Pencil
- Hammer
- Screwdriver
- Power drill
- Cable cutter
- Ladder
- Spirit level
- If there is no ceiling box or ceiling adapter, use appropriate plugs and screws suitable for the ceiling material:
  - 4 plugs (3/16")
  - 4 screws (M4)
- Mobile device (for onboarding purposes)

## Estimated installation time:

- Nobi Power installation will take approximately 15 minutes

### Before you begin:

- **Read all safety precautions** before starting the installation.
- The use of this manual is **restricted to Nobi Customer Services, authorized Nobi resellers, and technically trained individuals** who have received official Nobi installation training.

# Safety Precautions

**Read the following safety precautions carefully before installing the Nobi Power 2.1**



- Familiarize yourself with this manual and the product before installation. Service is guaranteed until 5 years after the EOL of the product. The expected service life is 10 years.
- When installing the Nobi Power, be aware of the risk of electric shock.
- This product must be installed in accordance with the applicable installation code by a person familiar with the construction and operation of the product and the hazards involved.
- The Nobi Power shall be installed in an electrical circuit that contains a circuit breaker with a minimum contact separation of 1/10".
- A surge protective device (SPD) must be installed upstream on each phase of the Nobi Power 2.1 as part of the building installation.
- The SPD (rated up to 2500 V peak) must comply with EN/IEC 61643-11.
- The Nobi Power is for indoor use only.
- The Nobi Power shall not be mounted inside a closet.
- The Nobi Power shall not be installed in a bathroom or restroom.
- The Nobi Power must be mounted on the ceiling.
- The Nobi Power is designed to support a maximum static load of 11 lbs or 5 kg. Under no circumstances shall the Nobi Power be subjected to a load exceeding this stated limitation.
- Service may only be performed by the manufacturer or its service agent.
- Once installed, the equipment is not intended for direct physical contact by any person.

# Installing the Nobi Power



## Pre-installation

- 1** **Locate the main circuit breaker box and switch off the electrical power.**  
To cut off power to individual rooms or circuits, switch the branch fuse to the OFF position.

Use a multimeter (or a known connected switch) to **verify** that the **power is fully disconnected**.

- 2** **Remove the current light fixture (if present), exposing 3 electrical wires:** ground (green or bare), neutral (white), and switched hot (black).  
Make sure you can identify each wire correctly. The colors may vary by country or local regulations. Tape or cap any unused ground wires.

**Notice:** The switched line must be bridged to the live line behind the switch controlling the lighting point where the Nobi Light will be installed, ensuring the lighting point has constant mains voltage (100 V-240 V).

- 3** **Take the Nobi Power out of the box.**

# Mounting the Nobi Power

- 4**
- If a **CEILING BOX (US)** is **PRESENT** or an existing light is replaced: **Connect the ceiling adapter to the ceiling box** using the 2 screws provided with the ceiling box.
  - If **NO CEILING BOX** is **PRESENT**, or if you are installing a new light: **Mark the 4 drill holes** with a pencil by holding the Nobi Power against the ceiling.

**Drill the holes** to the appropriate depth using a 15/64" or 6.0 mm drill bit at the marked points.

Carefully **tap the plugs** into the drilled holes.

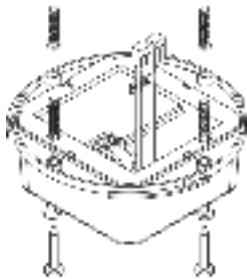

Precise marking is critical to the accuracy and ease of the subsequent steps.

- 5**
- Hold the Nobi Power against the ceiling** near the outgoing electrical wires.

- 6**
- Connect the electrical wires** to the Nobi Power by using the 2 connectors. Connect the switched hot (black) wire and the neutral wire (white) to the appropriate wires on the Nobi Power. Do not connect them to the same connector. The ground wire (green or bare) should not be connected. Tape or cap any unused ground wires.

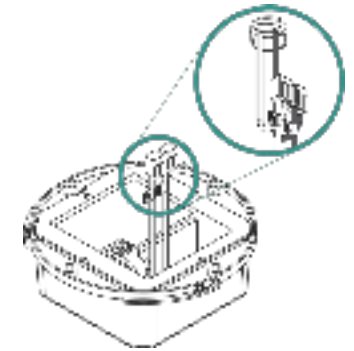

- 7**
- Mount the Nobi Power with the four screws.**
- If a **CEILING BOX (US)** is **PRESENT** or an existing light is replaced: Use the 4 included metric screws.
  - If **NO CEILING BOX** is **PRESENT** or a new light is being installed: Use 4 screws that are applicable to the ceiling material being used.





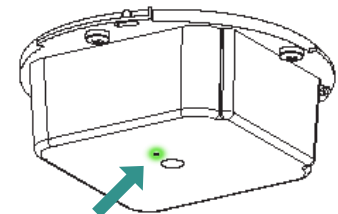







Tighten the screws, ensuring the Nobi Power is firmly fixed to the ceiling. Use all 4 screws for a sturdy installation.

- 8**
- Switch the fuse back on.** A small green light on the Nobi Power will illuminate.



# Warnings for the Nobi Power

## Symbols

	Consult manual before use		Indoor use only		UK Conformity Assessed		Warning sign
	Caution, risk of electric shock		FCC marking		Location of manufacturing		Read manual before use
	Class II		CE marking		Recycling		DC polarity
	Ceiling mount use only			Caution is needed when installing and using this device; consult the manual before use			

## Label

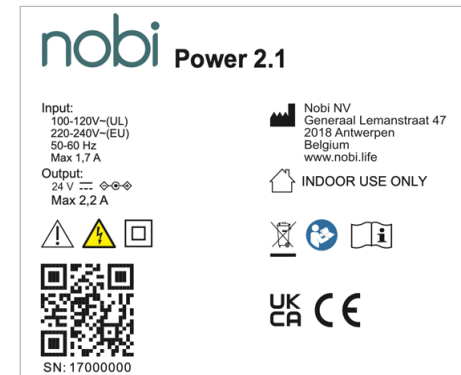

## Environmental conditions

- Operating temperature: 50 °F to 104 °F / 10 °C to 40 °C
- Operating humidity: 15% to 95% RH (non-condensing)
- Atmospheric pressure: 9.6 to 15.4 psi / 66 kPa to 106 kPa and maximum 6560 ft / 2000 m altitude

## Technical specifications

Nobi Power 2.1

Input

- 100-120 V AC (UL)
- 220-240 V AC (EU)
- 50/60 Hz
- Max 1.7 A

Output

- 24 V DC
- Max 2.2 A

## Disposal message

Your product is designed and manufactured with high-quality materials and components, which can be recycled and reused. Please find out for yourself about the local separate collection system for electrical and electronic products. Please follow your local regulations and do not dispose of this product with regular household waste. The correct disposal of your old product will help prevent potential negative consequences for the environment and human health.